

High- Efficiency Transformer less Interleaved Boost DC-DC Converter for High-Power PEM Fuel Cell Application

A.Ganesan^{1,*}, V.Balaji²

¹ Department of EEE, Dr. M.G.R Educational and Research Institute University, Chennai, India

² School of Electrical Engineering, Bahir Dar University, Ethiopia

*Corresponding author email: dragmephd@gmail.com

ABSTRACT

In this research work a novel transformer less interleaved boost dc-dc converter for a fuel cell application is proposed. In this paper a fuel cell with a electric application, of a high power boost dc-dc converter is adopted to adjust the output voltage, current and power of fuel cell to meet requirements. The challenge in designing a boost converter for high power application is how to handle the high current at the input side and it has high switching loss. In this work an interleaved boost dc-dc converter is proposed with the absence of transformer. This converter reduces the fuel ripple current. Since the fuel cells are costly, an equivalent electrical circuit is implemented instead of a fuel cell.

1. INTRODUCTION

The renewable energy such as fuel cell is considered as alternative to fossil energy mostly for reasons of pollution and efficiency. The proton exchange membrane fuel cell (PEMFC) has been considered as a promising kind of fuel cell during the last 10 years because of its low working temperature, compactness and easy and safe operational modes.

The traditional type of Dc-Dc converters are important in portable electronic devices which are supplied with power from batteries primarily. Switched DC to DC converters offer a method to increase voltage from a partially lowered battery voltage thereby saving space instead of using multiple batteries to accomplish the same thing. Most DC to DC converters also regulate the output voltage. The interleaved Dc-Dc converter is used to achieve low input –current ripple and high efficiency power conversion by the develop ripple cancellation characteristics at the high current side.

1.1 Fuel Cell

The fuel cell is drawing the attention by researchers as one of the most promising power supply in the future. Due to high efficiency, high stability, low energy consumed and friendly to environment, this technology is in the progress to commercialize. Fuel cell has higher energy storage capability thus enhancing the range of operation for automobile and is a clean energy source.

PROTON exchange membrane (PEM) fuel cell is a device that converts chemical fuels into electric power,

with many advantages such as clean electricity generation, high-current output ability, high energy density, and high efficiency. The PEM fuel cell presents a low voltage output with a wide range of variations. For the PEM fuel-cell system applications, the dc–dc converter must be concerned with the following design criteria: large step-up ratio, low-input-current ripple, and isolation.

1.2 Equivalent Model for Fuel Cell

Fuel cells of various types are considered as alternatives to fossil energy mostly for reasons of pollution and efficiency. The proton exchange membrane fuel cell (PEMFC) has been considered as a promising kind of fuel cell during the last 1years because of its low working temperature, compactness, and easy and safe operational modes. The proton exchange membrane (PEM) fuel cell is very simple and uses a polymer (membrane) as the solid electrolyte and a platinum catalyst.

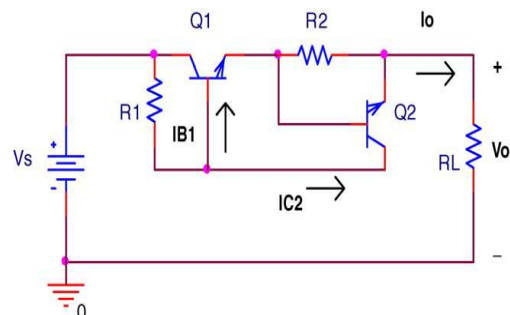

Fig.1 Proposed circuit model of PEM fuel cell module

The hydrogen from a pressurized cylinder enters the anode of the fuel cell and the oxygen (from air) enters the cathode. Protons and electrons are separated from hydrogen on the anode side. In a basic PEM cell, the protons are transported to the cathode side through the polymer and the electrons are conducted through the load outside the electrode. A fuel cell stack is composed of several fuel cells connected in series separated by bipolar plates and provides fairly large power at higher voltage and current levels.

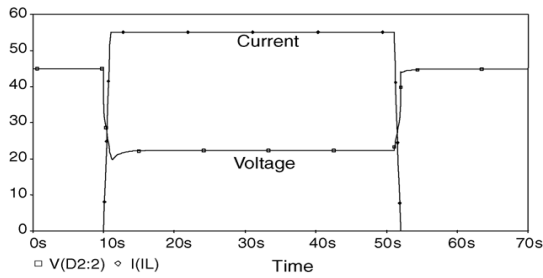

Fig. 2 Simulated waveforms of fuel cell
($C=1F, L_s = 10\text{ mH}$)

There is a need to model the PEMFC for optimizing its performance and also for developing fuel cell power converters for various applications. Almost all the models proposed for the PEMFC consist of mathematical equations and are not of much use in power converter/system simulation and analysis. Other models of PEMFC use Matlab–Simulink, but they are still mathematical in nature. The models include several chemical phenomena present in the fuel cell and hence are complex. Some of the physical variables like pressure and hydrogen input are constrained in a commercial fuel cell module and this makes the fuel cell operation simpler. This also allows the use of a simpler electric circuit model useful to a power electronics designer.

The model uses the nonlinearity of a junction diode and the current control feature of bipolar junction transistors (BJTs). In the proposed model, a diode is used to model both the activation losses and the ohmic losses in a PEMFC, while two BJTs are used to model the mass transport losses.

2. INTERLEAVED DC-DC CONVERTER

The interleaved dc–dc converter shown in Fig. 3 is designed and implemented to achieve low input-current ripple and high-efficiency power conversion by the developed ripple cancellation characteristics at the high current side and voltage-doubler topology at the high-voltage side. Because the fuel-cell stack lacks storage ability for electric energy, an energy-storage device such as the Li-ion battery is usually used on the high-voltage output dc bus of the power converter in practical high-power applications.

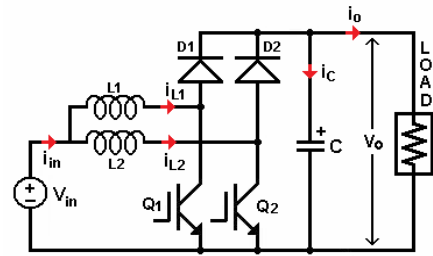

Fig. 3 Interleaved Boost DC-DC Converter

The interleaved boost dc-dc converter consists of two parallel connected boost converter units, which are controlled by a phase-shifted switching function (interleaved operation). Since this converter has two parallel units, the duty cycle for each unit is equal to $(V_{out}-V_{in})/V_{out}$, and it is same for each unit due to parallel configuration. A phase shift should be implemented between the timing signals of the first and the second switch. Since there are two units parallel in this converter, the phase shift value is 180.

2.1 EXISTING MODEL SYSTEM DESCRIPTION

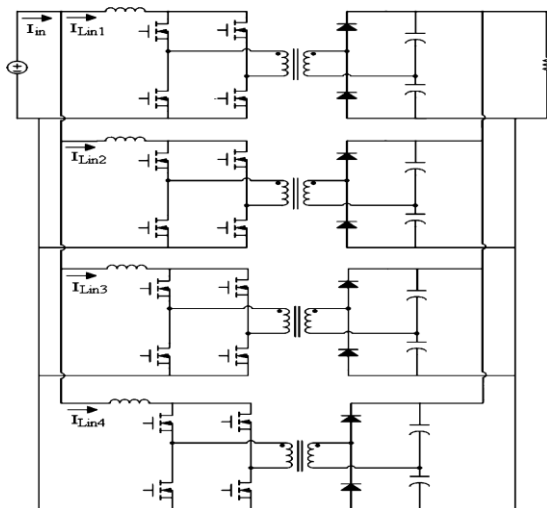

Fig. 4 General interleaved DC-DC converter

The current-fed full-bridge dc–dc converter composed with an input choke L_{in} , power switches $QA \sim QD$, a step-up transformer $T1$, and a secondary voltage doubler. The input choke L_{in} acts as a boost inductor to store and release the energy from the fuel-cell stack in accordance with the primary switches' operation. The duty cycle D for power switches $QA \sim QD$ is always higher than 50% to retain the continuity of the input inductor current I_{Lin} .

The voltage doubler is added at the transformer secondary side to reduce the voltage stresses of the secondary rectifier diodes for the studied high-voltage output applications. V_{Np} and V_N represent the transformer primary and secondary voltages, respectively.

2.2 PROPOSED CIRCUIT MODEL

The fuel cell is given as the input to the proposed model of transformer less interleaved dc-dc converter. The interleaved boost dc-dc converter of proposed model has only two switches. The switches are generally a MOSFET which are operated or triggered by a PWM generator. Since the transformer is reduced, the switching loss is considerably low and the fuel ripple current is reduced by the interleaved dc-dc converter. Fig 5 shows the proposed model of the interleaved boost dc-dc converter.

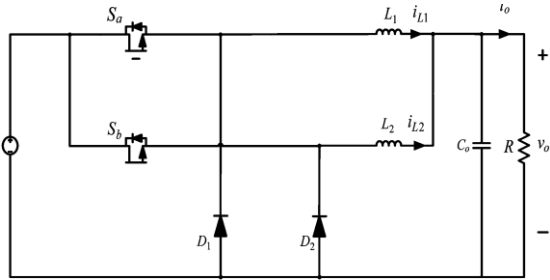

Fig. 5 Proposed interleaved dc-dc converter

3. SIMULATION MODEL

The simulation model of the transformer less interleaved boost Dc-Dc converter with fuel cell an input is designed using MATLAB and it is shown in fig 6 and the resultant wave form is shown in fig 7.

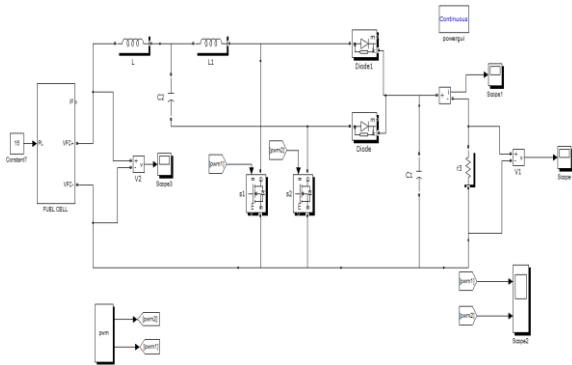

Fig. 6 simulation model of transformer less interleaved boost dc-dc converter with fuel cell as input

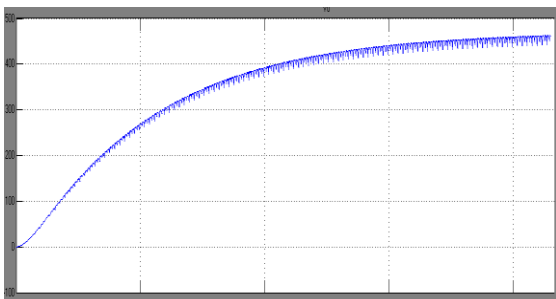

Fig. 7 The input voltage waveform for the simulation model

6. CONCLUSION

The voltage loss in considerably reduced in the proposed model. The input voltage is boosted up efficiently by using the transformer less interleaved boost dc-dc converter are obtained as shown in table.

Parameters	Existing converter	Proposed converter
Input Voltage(V)	50	50
Output Voltage(V)	200	198.8

REFERENCE

- [1]. D.D.C. Lu and V. G. Agelidis, Photovoltaic-battery-powered dc bus system for common portable electronic devices, *IEEE Trans. Power Electron.*, 24, 2009, 849–855.
- [2]. K. Sun, L. Zhang, Y. Xing, and J. M. Guerrero, A distributed control strategy based on dc bus signaling for modular photovoltaic generation systems with battery energy storage, *IEEE Trans. Ind. Electron.*, 26, 2010, 3032–3045.
- [3]. H. R. E. Larico and I. Barbi, Three-phase push-pull dc-dc converter: Analysis, design, experimentation, *IEEE Trans. Ind. Electron.*, 59, 2012, 4629–4636.
- [4]. M. Pahlevaninezhad, J. Drobniak, P. K. Jain, and A. Bakhshai, A load adaptive control approach for a zero-voltage-switching dc/dc converter used for electric vehicles, *IEEE Trans. Ind. Electron.*, 59, 2012, 920–933.
- [5]. R. L. Lin, C. C. Hsu, and S. K. Changchien, Interleaved four-phase buck-based current source with isolated energy-recovery scheme for electrical discharge machine, *IEEE Trans. Power Electron.*, 24, 2009, 2249–2258.
- [6]. C. Garcia, P. Zumel, A. D. Castro, and J. A. Cobos, Automotive dc-dc bidirectional converter made with many interleaved buck stages, *IEEE Trans. Power Electron.*, 21, 2006, 578–586.
- [7]. Y.C. Chuang, High-efficiency ZCS buck converter for rechargeable batteries, *IEEE Trans. Ind. Electron.*, 57, 2010, 2463–2472.
- [8]. C. S. Moo, Y. J. Chen, H. L. Cheng, and Y. C. Hsieh, Twin-buck converter with zero-voltage-transition, *IEEE Trans. Ind. Electron.*, 58, 2011, 2366–2371.